

Standard Features

- 6 clog-free, 26,000 BTU Burners
- Stainless steel front and shelf
- Galvanized sides
- Removable cast iron, flush-top grates
- Single-piece drip tray under burners
- Heat resistant door handle
- Commercial gas range 36.5" wide with a 37" cooking top (including 6" high adjustable legs)
- Hinged lower valve panel
- One year Parts and Labor Warranty

Griddle (1G)

- 12" griddle with 1/2" polished steel plate

Standard Oven (D Suffix)

- 32,000 BTU
- Large 26" wide x 26 1/2" deep oven -full sheet pans fit both ways
- Single rack per oven
- Equipped with a flame safety device
- Thermostat range from 250°-500°F (121°-260°C) with low setting

Convection Oven (A Suffix)

- 30,000 BTU
- Three racks per oven
- Full size sheet pan fits left to right
- Energy efficient flue design
- Manual pilot ignition, enamel bottom and door linings
- On/Off switch to allow CO base to operate as Standard oven

Standard Oven
336D/336D-1G

Convection Oven
336A/336A-1G



(shown with optional casters)

STANDARD CONSTRUCTION SPECIFICATIONS

Exterior Finish: Stainless steel front and shelf standard. Galvanized sides.

Range Top: 6 -26,000 BTU cast iron non-clogging burners (4-26,000 burners with the 12" griddle option). Removable flush top grates. Center-to-center measurements between burners not less than 12", side-to-side or front-to-back. Removable one piece drip tray provided under burners.

Griddle (1G): Smooth, polished, 1/2" thick steel plate with raised sides, 12" wide x 29 3/4" deep.

Back Shelf: Rigid, single deck stainless steel.

Interior: Cavity sides, top and back -aluminized steel. Oven bottom and door lining porcelain enamel finish. Four sides and top of oven insulated with heavy, self-supporting block type rock wool with oven baffle assembly constructed of Aluma-Ti steel.

Door: Constructed with heavy duty hinges and unbreakable quadrants and heat resistant handle.

Legs: 6" black, adjustable

Model 336D: 32,000 BTU with thermostat range of 150°F to 500°F. Porcelain enamel interior, measuring 14" high x 26" wide x 26.5" deep. Two position rack guides with one removable rack. Oven thermostat temperature type adjustable for 250°F to 500°F. Factory installed pressure regulator.

Model 336A: 30,000 BTU convection oven thermostat range of 150°F to 500°F. Porcelain enamel interior, measuring 14" high x 26" wide x 24" deep. Three racks with 5-position side rails. Two-speed, 1/3 hp blower motor mounted to rear - serviceable from front. Gas Control System: Includes pressure regulator, flame switch safety, pilot filter, pilot adjustment, and manual oven surface shut-off valve.



Models: 336D 336A 336D-1G 336A-1G

Dimensions -in (mm)

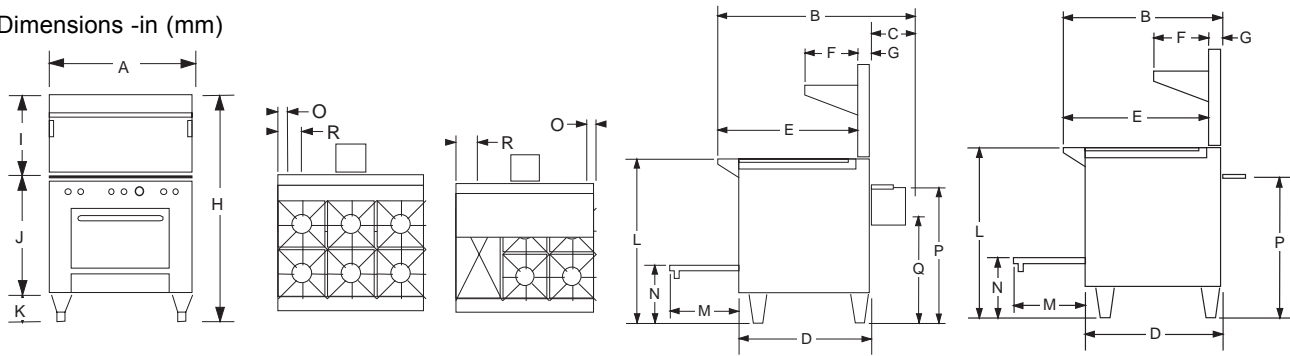

MODEL	Exterior										Cook Top	Door Opening	Oven Bottom	3/4" Gas Conn.		Electric		
	Width A	Depth B	C	D	E	F	G	H	I	J				K	L	M	N	O
336D 336D-1G	36.5" (927)	34" (864)	-	31.25" (756)	31" (787)	12" (305)	2.75" (70)	59.5" (1511)	22.75" (587)	30.75" (787)	6" (152)	37" (914)	15.5" (394)	13.0" (318)	2.5" (64)	30.25" (768)	-	-
336A 336A-1G	36.5" (927)	42.25" (864)	8" (203)	31.25" (756)	29.625" (787)	12" (305)	2.75" (70)	59.5" (1511)	22.75" (587)	30.75" (787)	6" (152)	37" (914)	15.5" (394)	13.0" (318)	2.5" (64)	30.25" (768)	24" (610)	6" (152)

MODEL	OVEN INTERIOR			BURNER (BTU each)			CRATE SIZE			CUBIC VOLUME	CRATED WEIGHT
	Width	Depth	Height	Open	Oven	Griddle (1G only)	Width	Depth	Height		
336D 336D-1G	26" (660)	26.5" (673)	14" (356)	6 (26,000) 4 (26,000)	1 (32,000)	2 (16,000)	44" (1118)	45.5" (1158)	48" (1219)	55.6 cu.ft (1.58 cu.m.)	535 lbs (317.8 kg)
336A 336A-1G	26.125" (664)	21.75" (552)	14.25" (362)	6 (26,000) 4 (26,000)	1 (30,000)	2 (16,000)	44" (1118)	45.5" (1158)	48" (1219)	55.6 cu.ft (1.58 cu.m.)	535 lbs (317.8 kg)

NOTES:

- Dimensions C on Model 336A; 336A-1G includes 2" minimum clearance between motor and wall.
- Optional -Hot Plate in lieu of 2 open top burners at 12,000 BTU/ burner (24,000 BTU total)

*BTU's in Natural Gas rating

UTILITY INFORMATION

Models: 336D; 336A

GAS:

- Total BTU: 336D -188,000; 336A -186,000
- Total BTU: 336D-1G -168,000; 336A-1G -166,000
- Required minimum inlet pressure
 - Natural gas 4" W.C.
 - Propane gas 10" W.C.
- Pressure regulator is supply with unit
- Required supply line size to the regulator is 3/4" NPT.

ELECTRICAL:

- Standard -115/60/1 furnished with 6' cord with 3-prong plug. Total max amps 4.8.
- Optional -208/60/1 or 3 phase (190 to 219 volts). Supply must be wired to junction box with terminal block located in rear. Total max amps 2.6
- Optional -236/60/1 or 3 phase (220 to 240 volts). Supply must be wired junction box with terminal block located in rear. Total max amps 2.6

MISCELLANEOUS

- If using Flex-Hose, the I.D. should not be smaller than 3/4" and must comply with ANSI Z 21.69
- If casters are used with flex hose, a restraining device should be used to eliminate undue strain on the flex hose
- For installation on combustible floors (with 6" high legs) and adjacent to combustible walls, allow 6" clearance.
- Install under vented hood
- Check local codes for fire, installation and sanitary regulations.

NOTICE:

Southbend has a policy of continuous product research and improvement. We reserve the right to change specifications and product design without notice. Such revisions do not entitle the buyer to corresponding changes, improvements, additions or replacements for previously purchased equipment.

OPTIONS AND ACCESSORIES

- 10" flue riser (no charge)
- 3/4" quick disconnect with flexible hose complies with ANSI Z 21.69 (specify 3', 4', 5')
- Casters in lieu of legs (all swivel, front with locks)
- S-36 Salamander Radiant Broiler
- CM-36 Cheesemelter
- MRA-36 Infrared Salamander Broiler
- Extra Oven Racks
- Stainless steel body sides
- 12" Griddle

**INTENDED FOR COMMERCIAL USE ONLY.
NOT FOR HOUSEHOLD USE.**



1100 Old Honeycutt Rd., Fuquay-Varina, NC 27526
www.southbendnc.com