



# STAR-MAX® 10 lb. ELECTRIC FRYER

## Model 510FD

### Features/Benefits:

- ★ Star-Max 10 lb. electric fryer offers excellent frying flexibility for a variety of menu items.
- ★ Compact fryer requires only 11" of counterspace and operates on a 120 volts.
- ★ One-piece 10 lb. lift-out nickel plated steel kettle is standard for easy straining of oils.
- ★ Two large nickel-plated steel mesh side hanging baskets (3-1/2"W x 4-5/8"D x 8-1/2"L) provide continuous flow of product during peak periods.
- ★ Immersion type tubular heating elements provide even heat distribution and swing up making cleaning a snap.
- ★ Snap-action thermostat ranges from 200°F to 375°F and provides quick response to temperature change.
- ★ Hi-limit on-off switch and indicator light provides safe and easy operation.
- ★ All stainless steel construction for maintenance free operation.
- ★ Adjustable legs to match the height of other Star-Max equipment in your line.
- ★ Accessory full basket (3-1/2"W x 4-5/8"D x 8-1/2"L) available.

### Applications:

Star-Max 510FD compact fryer plugs in anywhere. Perfect for lower volume restaurants, rental facilities, snack bars and other foodservice operations. No matter what the menu items; onion rings, fries, chicken or fish, Star-Max electric fryer will meet your menu requirements.

### Quality Construction:

Star's electric fryer features all stainless steel construction with black polycarbonate trim, with an adjustable hi-limit safety thermostat. A one-piece nickel plated steel lift-out kettle with tubular two-position swing-up element. Unit supplied with two side mounted nickel plated baskets. Fryer is standard 120V with 6' lead-in cord and plug.

### Warranty:

Star-Max electric fryer is covered by Star's one year parts and labor warranty.



Model 510FD





Star Manufacturing International, Inc.

Star-Max® 10 lb. Electric Fryer

## STAR-MAX® 10 lb. ELECTRIC FRYER Model 510FD

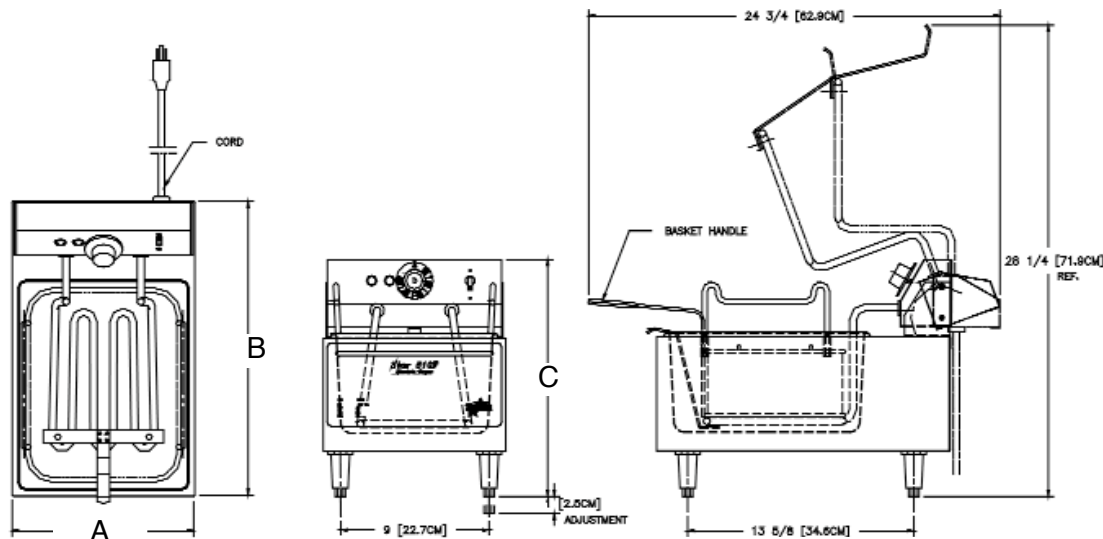

### Performance Data

Model No.	Fat Capacity	Pre-Heat to 350° F (177° C)	Pounds of French Fries Per Hour	Watts Per Hour To Maintain 350° (177° C)
510FD	10 lbs (4.5 kg)	9 Minutes	10 lbs. (4.5 kg)	450

### Dimensions & Weight

Model No.	Overall Dimensions			Fat Container			Cooking Surface Height	Approximate Weight	
	(A)	(B)	(C)	Width	Depth	Height		Installed	Shipping
	Inches (cm)	Inches (cm)	Inches (cm)	Inches (cm)	Inches (cm)	Inches (cm)	lbs. (kg)		
510FD	11 (28.0)	18 (46.0)	14 (35.5)	9 (23.0)	11 (28.0)	6 (15.2)	10 (25.4)	20 (9.0)	25 (11.3)

### Electrical Data

Model No.	Rated Wattage	Nominal Amps	NEMA Plug
510FD	1800	15	5-15P
	1800	15	5-20P*

\*Canadian Requirement

### Typical Specifications

A 200°F- 375°F (93°C - 191°C) adjustable thermostat and a hi-limit safety thermostat are provided. A separate on-off switch is standard. A one piece stainless steel lift-out 10 lb. (4.5 kg) capacity kettle is provided. Unit has a tubular, two position, swing-up element with a rated wattage of 1800 watts on 120 volts. Two side mounted nickel plated baskets are provided as standard. Black plastic adjustable legs are standard. Comes complete with a 6 ft. (182.9 cm) lead-in cord and NEMA 5-15P. (NEMA #5-20P, 120V, 20A on Canadian versions) Unit carries approval of Underwriters Laboratories, C-UL, and National Sanitation Foundation. Printed in the U.S.A.

Due to periodic changes in designs, methods, procedures, policies and regulations, the specifications contained in this sheet are subject to change without notice. While Star Manufacturing exercises good faith efforts to provide information that is accurate, we are not responsible for errors or omissions in information provided or conclusions reached as a result of using the specifications. By using the information provided, the user assumes all risks in connection with such use.

Star Manufacturing International Inc. - 10 Sunnen Drive - P.O. Box 430129 - St. Louis, MO 63143-3800

Phone: (800) 264-7827 - FAX: (800) 264-6666 - www.star-mfg.com