

Project

Item #

Quantity



GLOBE FOOD EQUIPMENT COMPANY

40 Quart Mixer

SP40P



SP40P Mixer

Model

SP40P - 40 Quart Mixer



Standard Features

- 2 HP custom built motor
- Three fixed speeds
- High torque transmission
- Heat-treated hardened steel alloy gears and shafts
- Permanently lubricated transmission
- Thermal overload protection
- Rigid cast iron body
- Stainless steel bowl guard with built in ingredient chute
- NSF approved enamel gray paint
- Front mounted controls
- 15 minute timer
- Industry standard #12 attachment hub
- Safety interlocked bowl guard and bowl lift
- Non-slip rubber feet
- 6 foot cord and ground plug (single phase only)

Standard Accessories

- 40 quart stainless steel bowl
- Flat beater (aluminum)
- Stainless steel wire whip
- Spiral dough hook (aluminum)

Optional Attachments/Accessories

- Slicer/shredder/grater for #12 hub
- Meat grinder for #12 hub
- 20 quart adapter kit

Standard Warranty

- 2 years parts and one year labor

Approved By: _____

Date: _____



GLOBE FOOD EQUIPMENT COMPANY
www.globeslicers.com

2153 Dryden Rd
 Dayton, OH 45439
 Phone: 937-299-5493
 Phone: 800-347-5423
 Fax: 937-299-4147



40 Quart Mixer

SP40P

Specifications

Motor: 2 HP, grease packed ball bearing, air cooled, 220/60/1, 17 amps or 208/60/3, 8 amps. Thermal overload protection (automatic reset).

Finish: NSF approved enamel gray paint.

Capacity: 42 quart (40 liter) bowl.

Transmission: Fixed speed transmission is made of heat treated, hardened alloy, precision milled gears that operate the planetary action and provide high torque mixing power. The gears are packed in a long lasting grease, and all shafts are mounted in ball bearings.

Safety Interlocks: The bowl guard and bowl lift lever are interlocked. The mixer will automatically shut down when the guard is opened or the bowl is lowered.

Agitator Speeds (RPMs):

Low	74
Intermediate	132
High	272

Attachment Speeds (RPMs):

Low	52
Intermediate	92
High	190

Standard Equipment: Standard equipment includes a 40 quart #304 series stainless steel bowl, spiral dough hook, stainless steel wire whip, flat beater, stainless steel bowl guard with built in ingredient chute, 15 minute timer, and #12 attachment hub. A sturdy hand lever on the body column raises and lowers the bowl as well as locking in place at the top and bottom positions.

Cord: The single phase has a three wire cord and ground plug (6-20P). The three phase is hard wired.

Dimensions:

Foot Print = 25.0" x 24.5"
(63.5 cm x 62.2 cm)
Overall Length = 28.4" (72.1 cm)
Overall Width = 25.0" (63.5 cm)
Overall Height = 51.0" (129.5 cm)

Shipping Information:

Freight Class: 85
Net Weight: 550 lbs. (250 kgs.)
Shipping Weight: 720 lbs.(325.8 kgs.)
Shipping Dimensions:
42"W x 48"D x 65"H
(107.7cm W x 121.9cm D x 165.1cm H)
Cartons are affixed to a skid (pallet). The weight and dimensions of this skid are included above and may vary from shipment to shipment.

Optional Accessories:

XXACC20-40 Adapter Kit includes a 20 quart bowl, wire whip, dough hook, flat beater, and bowl adapter to adapt 40 quart mixer to a 20 quart capacity.

Optional Attachments:

XMCA-SS Meat Grinder Assembly (Polished stainless steel cylinder, worm, ring, and pan. Includes knife, 3/16" plate, stainless steel pan, and pusher.)

Chopper Plate Sizes Available:

CP02-12	1/16"	(2mm)
CP04-12	5/32"	(4mm)
CP05-12	3/16"	(5mm)
CP06-12	1/4"	(6mm)
CP08-12	5/16"	(8mm)
CP10-12	3/8"	(10mm)
CP12-12	1/2"	(12mm)
CP14-12	9/16"	(14mm)
CP16-12	5/8"	(16mm)
CP18-12	11/16"	(18mm)
CP00-12	Stuffing Plate	
XST12	1/2" stuffing tube (sheep)	
XST34	3/4" stuffing tube (hog)	

XVSGH 9" Slicer/Shredder/Grater Housing Only (*no plates included-must select from plates below*)

XASP Adjustable slicing plate

XPH Plate holder - *only 1 required

Shredding/Grating Plates:

XSP332*	3/32"	(2.3mm)
XSP316*	3/16"	(4.7mm)
XSP14*	1/4"	(6.3mm)
XSP516*	5/16"	(7.9mm)
XSP12*	1/2"	(12.7mm)
XGP*	Grating plate	

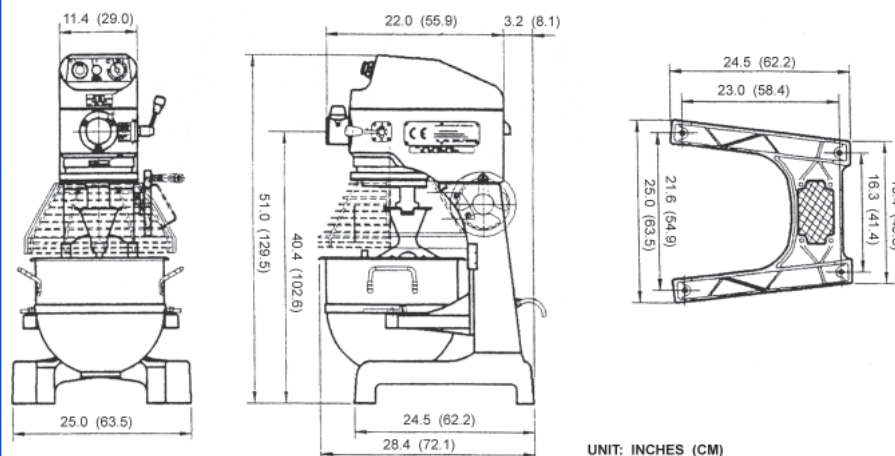

GLOBE FOOD EQUIPMENT COMPANY
www.globeslicers.com

2153 Dryden Rd
Dayton, OH 45439
Phone: 937-299-5493
Phone: 800-347-5423
Fax: 937-299-4147

Printed In U.S.A. 3-2007

Specifications are subject to change without notice.