

SM50 Series Ice Cube Machine



SM50 Series



- Produces 53 lbs. (24 kgs.) of ice in 24 hours with storage capacity of 25 lbs. (11 kgs.)
- Individual cubes with unique octagon shape
- Designed to be installed into standard cabinet dimensions 15.00" (38.00 cm) or stand alone with stainless steel top and sides standard
- Unit ships with hinge on right, easily changed to left during installation
- Easily accessible control panel with the following functionality:
 - Automatic ice making mode
 - Patented cleaning and sanitizing
 - Delay start option
 - Filter replacement warning light
- Water filter system integrated inside machine with depth filtration and scale inhibitor
- Lighted bin (LED light) with large opening for easy access
- Optional drain pump easily integrates inside the machine during installation
- 3-year parts and labor warranty on entire machine

Note: This product is intended exclusively for commercial application. No warranty is extended for personal, family, or household purposes.

America's #1 Selling Ice Machine

Ice Cube & Flake Machines • Ice Storage Bins • Ice Dispensers

Manitowoc
Foodservice Group

Manitowoc SM50 Series

Model	Cube size	Ice production 24 hours		Power kWh/100 lbs.
		lbs.	kgs.	
SM50A	Standard	53	24	11.89
Water usage/100 lbs./45.4 kgs. of ice				
Potable Water: 48 gallons, 182 liters				

*A following model number indicates "Air" cooled condensing unit.

Ice Machine Electric

115/60/1. Factory pre-wired with a 6' (180 cm) power cord and NEMA 5-15P-plug configuration.

Total Amps: 4.1 amps.

Maximum Fuse Size: 15 amps.

HACR-type circuit breakers can be used in place of fuses.

Specifications

BTU Per Hour:

1,145 (average) 2,300 (peak)

Compressor:

Nominal rating: 1/6 HP

Operating Limits:

• Ambient Temperature Range:

50° to 110°F (10° to 43°C)

• Water Temperature Range:

35° to 90°F (2° to 32°C)

• Water Pressure Ice Maker

Water In:

Min. 20 psi (138 kPa)

Max. 80 psi (551 kPa)

Legs:

Levelers standard 0" to 1"

(0-2.5 cm) adjustability.

Optional legs 4.25"-6.00"

(10.80-15.24 cm).

Insulation:

Insulation foamed-in-place with CFC-FREE foam.



Air Flow Front View

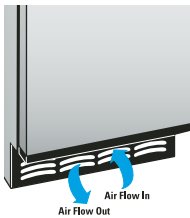

Air in right, air out left, no side vents.

Water Filter



Auto-bypass for easy change out.

Cube Size

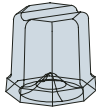

Standard
1-3/8" x 1-3/8"
(33 x 34 mm)

Front Access Control Panel



Machine automatically keeps the bin full. Choose delay start for optimal quietness. Machine automatically restarts.

24-HOUR PRODUCTION †		lbs. kgs.	
AIR-COOLED UNIT			
air temp	water temp		
°F	50°	70°	90°
°C	10°	21°	32°
70°	53	53	53
21°	24	24	24
80°	50	49	48
27°	23	22	21
90°	48	44	43
32°	21	20	19

†16 cubes per ice cycle.

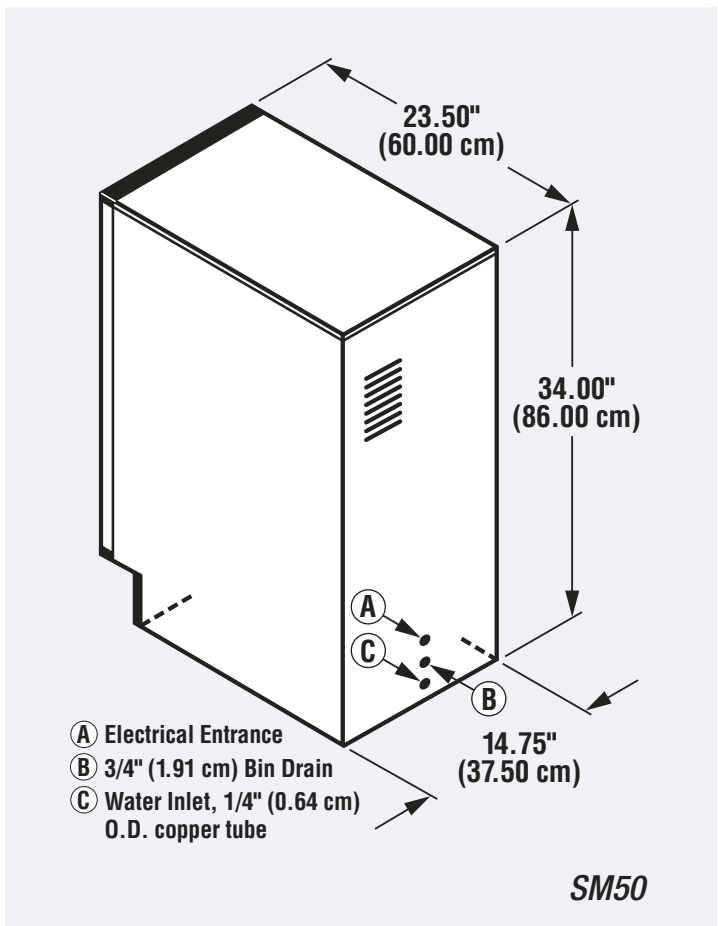

Installation Note - There is no minimum clearance required, designed to be integrated into cabinet opening 15.00" (38.00 cm) wide.

©2006 Manitowoc 1/06 Continuing product improvement may necessitate change of specifications without notice. 3404B Web



MANITOWOC ICE, INC.
2110 South 26th Street, P.O. Box 1720
Manitowoc, WI 54221-1720, USA
Ph: 920-682-0161 • Fax: 920-683-7589
Visit us online at www.manitowocice.com

