

INSULATED HOT CABINET MODEL H-137-UA-12C

FEATURES AND BENEFITS:

- Fully insulated hot cabinet keeps prepared foods at serving temperatures.
- Powerful, yet efficient, 1500 Watt heating system maintains the right temperature to properly hold products. Heats up to 200°F. (93°C.).
- Self-contained power top allows interior of cabinet to be hosed-out during cleaning.
- Internal frame in body and doors maintains structural rigidity.
- Body constructed of non-corrosive, Hi-Tensile aluminum for strength and ease of mobility. One piece extended base protects cabinet body.
- Smooth interior coved corners prevent food particle/grease buildup.
- Self-closing insulated Dutch doors prevent temperature loss; magnetic door gaskets for proper seal. Field reversible for flexibility.
- Standard with right hand hinging; left hand hinging available upon request.
- Full length extruded door handles for “easy open”; positive catch secures door during transport.
- Recessed push/pull handles on both sides prevents damage to walls; allows easy maneuvering.
- Twelve sets of chrome plated wire universal angles accommodate a large variety of pan sizes on adjustable 1-1/2" centers.
- Heavy duty 5" swivel casters, two with brakes. Provides mobility when fully loaded.



H-137-UA-12C



ACCESSORIES and OPTIONS (Available at extra cost):

- Tempered Glass Door Windows
- Extra Universal Angles
- Change from standard chrome plated wire angles to angles designed for transporting
- Change from chrome plated wire angles to extruded aluminum or formed stainless steel angles.
- Corner Bumpers
- Perimeter Bumper
- Floor Lock (for use with 5" casters)
- Various Caster Options
- Removable Cord Set
- 208 or 240 Volt Service
- Food Safe Digital Thermometer
- Magnetic Door Latch
- Upgrade to 2000 Watt Power Unit

See page B-20 for accessory details.

H-137-UA-12C

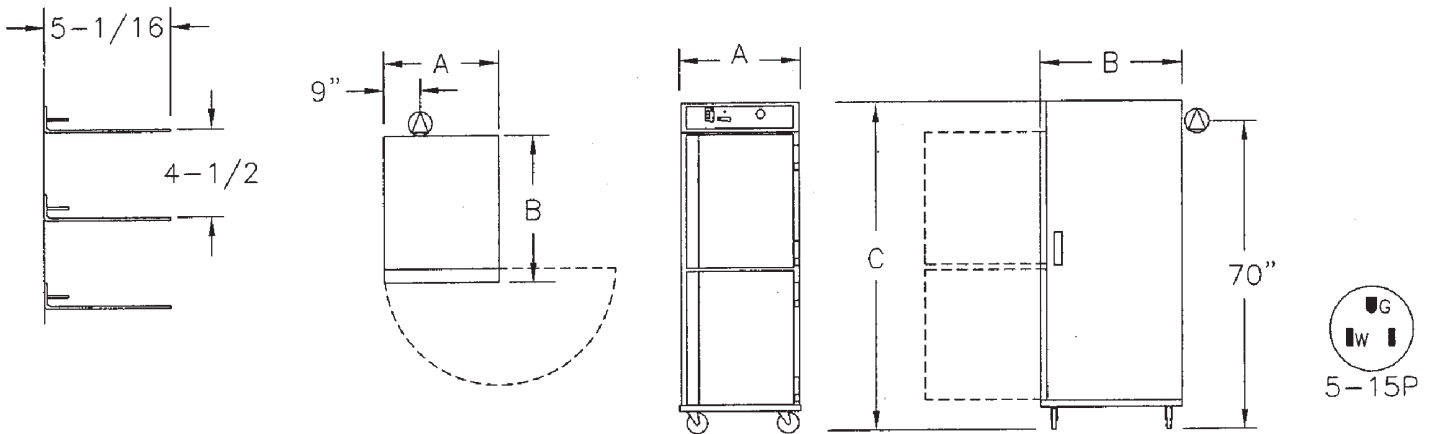

CRES COR MODEL NO.	PAN			DIM "A"	DIM "B"	DIM "C"	INSIDE DIMENSIONS				WEIGHT ACT.
	CAP/ANGLES	SIZE		WIDTH	DEPTH	HEIGHT	WIDTH	DEPTH	HEIGHT		
H-137-UA-12C	12 SETS	SEE NOTE BELOW	IN	28-3/4	34-3/16	73	22	27-1/2	58	LBS	255
			MM	730	870	1855	560	700	1475	KG	116

NOTES: 1. Pan sizes 22" x 20" (560 x 510) Roast & Bake Pans, 10" x 20" (255 x 510) Roast & Bake Pans, 18" x 26" (460 x 660) Bun Pans, 14" x 18" (355 x 460) Service Trays, 12" x 20" (305 x 510) Steam Table Pans.
Refer to Pan Size Chart at end of section.

2. When ordering bumpers, add 2" to overall dimensions.

ALL CONSTRUCTION IS RIVETED, WELDED AND FINISHED.

CABINET:

- Body: .063 aluminum.
- Reinforcement: Internal framework of 18 ga. 304 stainless steel.
- Insulation: Fiberglass, thermal conductivity (K factor) is .23 at 75°F. 1-1/2" in doors, top, base; 2" in sidewalls.
- Air tunnel: 22 ga. 304 stainless steel; lift-out type, mounted on back.
- Push/pull handles (2): 5" vertical; recessed.
- Interior coved corners.

BASE:

- One piece construction, .125 aluminum.
- Casters: 5" dia., swivel, modulus tires, 1-1/4 wide, load cap.
- 250 lbs. each, temp. range -45°/+180°F. Delrin bearings. Front casters equipped with brakes.

DUTCH DOORS:

- Field reversible.
- Exterior: .063 brushed aluminum.
- Interior: 22 ga. 430 stainless steel.
- Latches: Positive transport type with lock hasp.
- Extruded handles.
- Hinges: Self closing, stays open past 90°.
- Gaskets: Perimeter type, magnetic Santoprene.
- Pan stops.

PAN SLIDES:

- Wire angles (.306 dia.), nickel chrome plated steel, mounted on lift-off posts.
- Spaced on 4-1/2" centers; adjustable on 1-1/2" centers.

HOT UNIT COMPONENTS:

- Top mounted; removable with tools.
- Thermostat: Mechanical, room ambient to 200°F. (93°C.).
- Switch: ON-OFF rocker type.
- Power light.
- Power cord: Permanent, 10 ft., 14/3 ga.
- Heater: 1470 Watts.
- Blower motor.
- Vent fan.
- Thermometer: Analog

POWER REQUIREMENTS:

- 1500 Watts, 125 Volts, 60 Hz., single phase, 12 Amps., 15 Amp. service.

SHORT FORM SPECIFICATIONS

Cres Cor Insulated Hot Cabinet Model H-137-UA-12C. Inner, outer and top liners of .063 aluminum; stainless steel internal frame. (12) sets wire universal angles for multiple pan sizes, adjustable spacing every 1-1/2". Field reversible Dutch doors, outer .063 brushed aluminum, inner 22 ga. 430 stainless steel. Fiberglass insulation in sides 2"; doors, top, base 1-1/2". Interior coved corners. Hose out cleaning capability. 1500 Watt, 125 Volt power unit. One piece base, .125 aluminum. 5" swivel modulus casters, Delrin bearings. Load capacity 250 lbs. each. 2 year parts warranty. Provide the following accessories: _____ . NSF, UL, CUL listed, Energy Star Qualified.



5925 Heisley Road • Mentor, OH 44060-1833
Phone: 877/CRESCOR • Fax: 440/350-7267
www.crescor.com

© Crescent Metal Products, Inc. 2006 All rights reserved.

In line with its policy to continually improve its products, CRES COR reserves the right to change materials and specifications without notice.

Litho in U.S.A.