

Arctic Air Commercial Dual-Temp Wine Cellar



Shown Model DTW100. See back page for specifications.

DTW100 Wine Cellar features two separate compartments and temperature zones, locks, lights, digital displays, black exterior with stainless steel doors, front venting, sliding shelves, and 100 Bordeaux size bottle capacity.



It's not only easy to see what's inside— it's easy to see why these are such a great buy.

- Two full-view stainless steel doors with double-pane glass
- 100-bottle capacity (bottles vary in size — capacity may vary slightly)
- Bottles vary in size and capacity
- Two separate compartments
- Individual digital temperature controls and readouts
- Temperature range from +46° to +64°F
- Ideal conditions for red, white and sparkling wines



- Dark grey interior cabinets light up on command
- Slide-out, backstop, chrome-plated racks
- Front-vented for built-in applications
- Fans circulates inside air
- Independent lock and key for each door
- Heavy duty leveling legs
- UL-listed

These quiet, economical Arctic Air Wine Cellars come with a full warranty:
5 years on compressor, 1 year parts and labor.

MODEL #DTW100 WINE CELLAR

Capacity:

100 bottles (50 per side)

Unit Dimensions:

Height 59.8"
Width 26.0"
Depth 30.5"

Shipping Dimensions:

Height 62.6"
Width 29.9"
Depth 30.9"

Unit Weight:

220.4 lbs.

Shipping Weight:

242 lbs.

Electrical Rating:

115 Volt, 60 Hz, 1.6A

Refrigerant:

R134a

© 2008 Broich Enterprises. All rights reserved.

Arctic Air Brand and Logo are registered trademarks of Broich Enterprises.

Products and specifications subject to change without prior written notice.

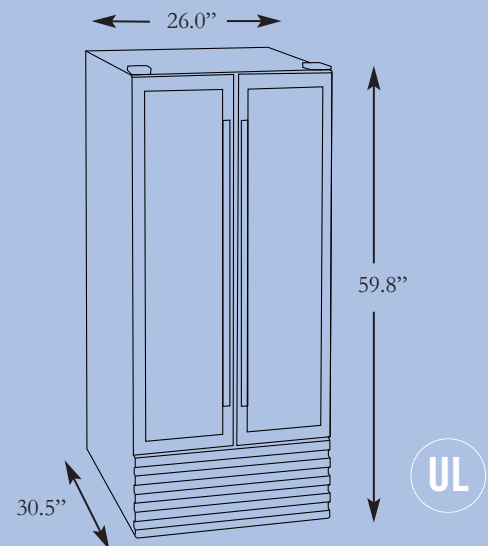

Use as a free standing cellar or as a built-in!



Commercial Freezers & Refrigerators

Division of Broich Enterprises, Inc. 6440 City West Parkway Eden Prairie, MN 55344
952-941-2270 Fax: 952-941-3066 www.articairco.com info@articairco.com